

auto electrical parts

Technical Information Sheet

Part No. 0-443-35

LED Beacon Light Bar, Amber, 12/24v, 4 Bolt Mount, 10 Flash Patterns, 72 x 0.5W LED's, 36W Max Power. IP67. 0.5M Flying Leads, E Marked R10 EMC.



Technical Drawing (not to scale)

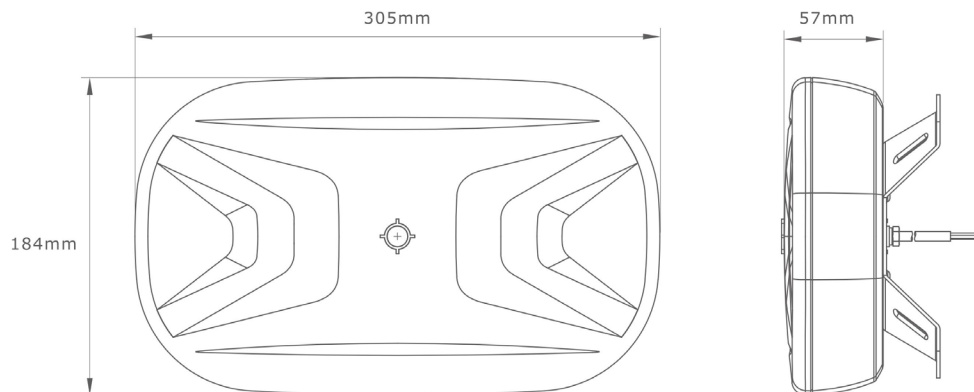

Specification

Type	LED Light Bar
Colour	Amber
Voltage	12/24V
Current	3A @ 12VDC
Number of LED's	72
LED Power	0.5W
Lens	Polycarbonate
Housing	ABS
Weight	1.5Kg
Dimensions	305*184*57mm
IP Rating	IP67
Flash Patterns	10
Compliance	E Marked ECE R10 EMC

The information contained in this document is correct to the best of our knowledge at the time of printing. However, specifications may change at any time without notice.